



GEDA USA, LLC

1151 Butler Rd. • League City, TX 77573

Phone: 713-621-7272 • Fax: 713-621-7279 • Toll-Free: 1-866-973-4332

www.gedausa.com • sales@gedausa.com

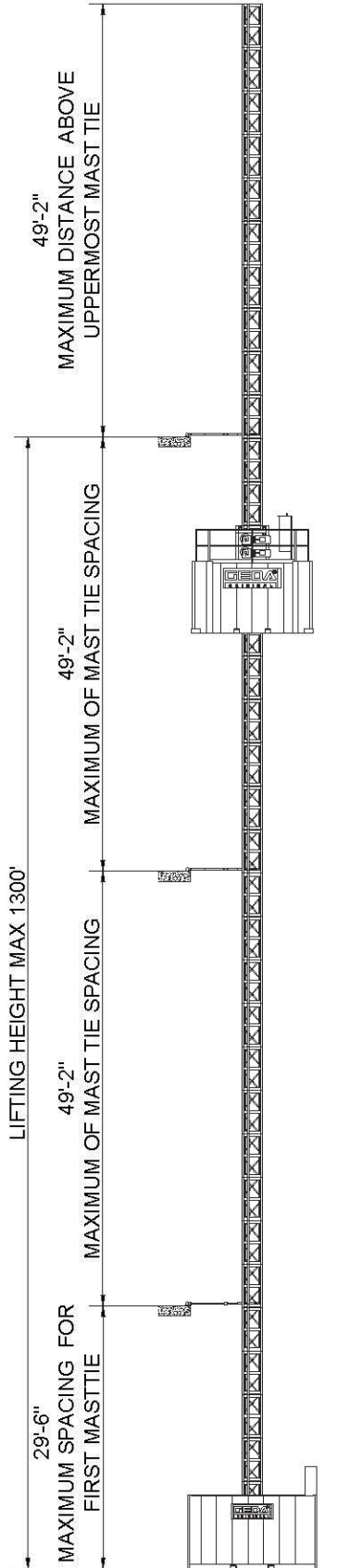

ELEVATION VIEW

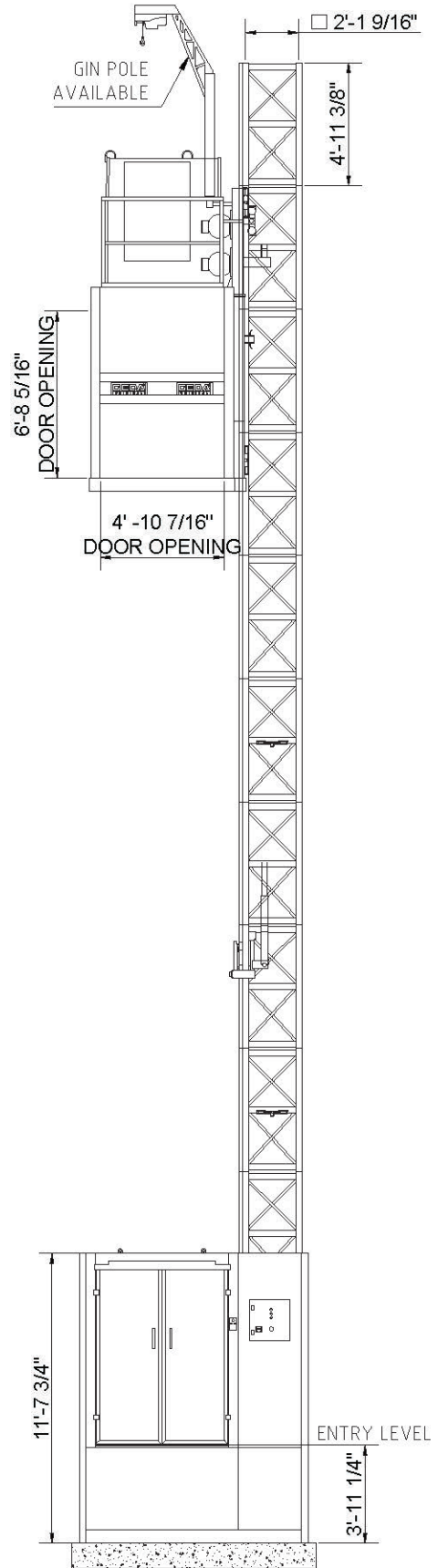

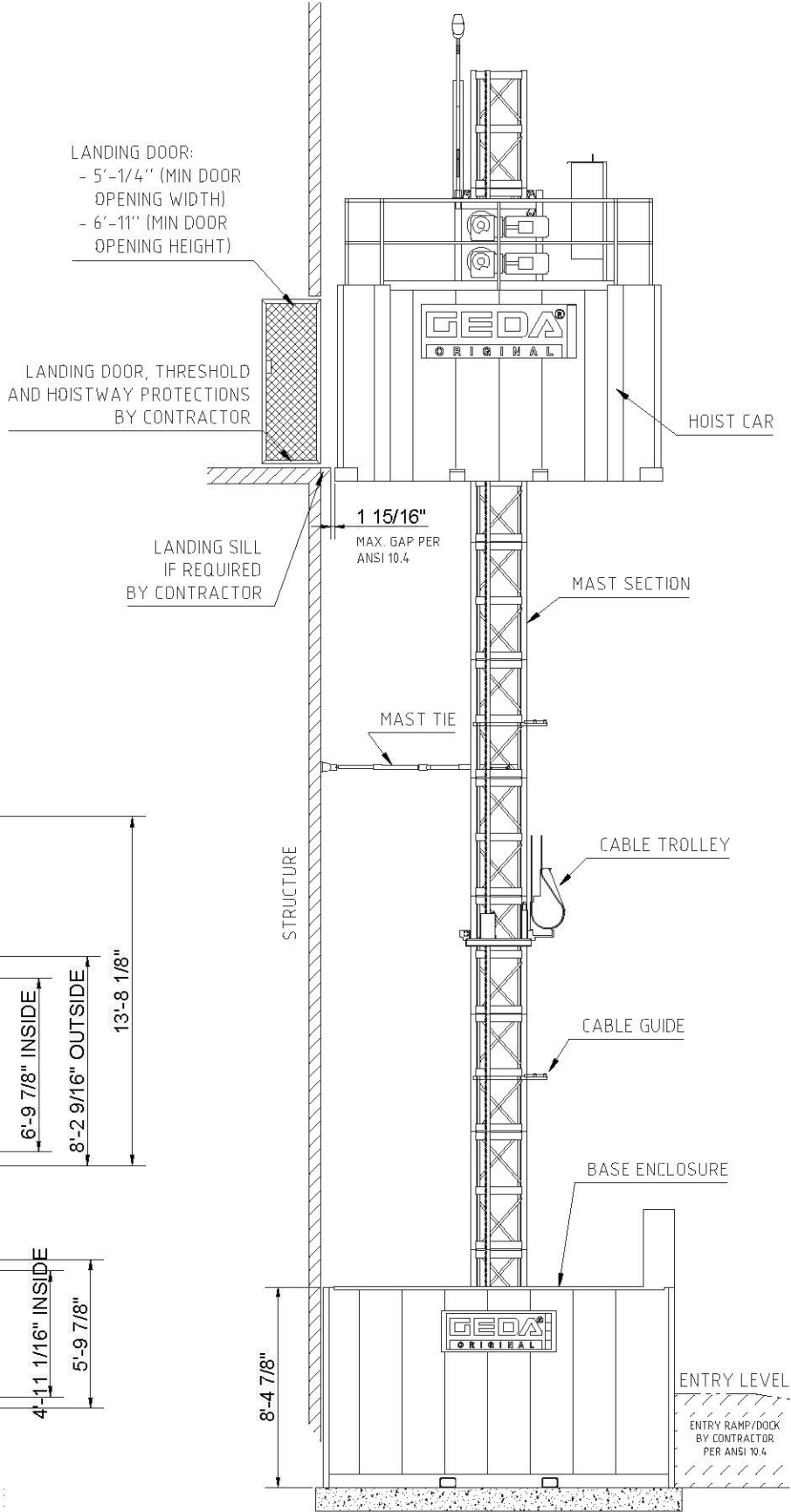

DIMENSIONS CAR

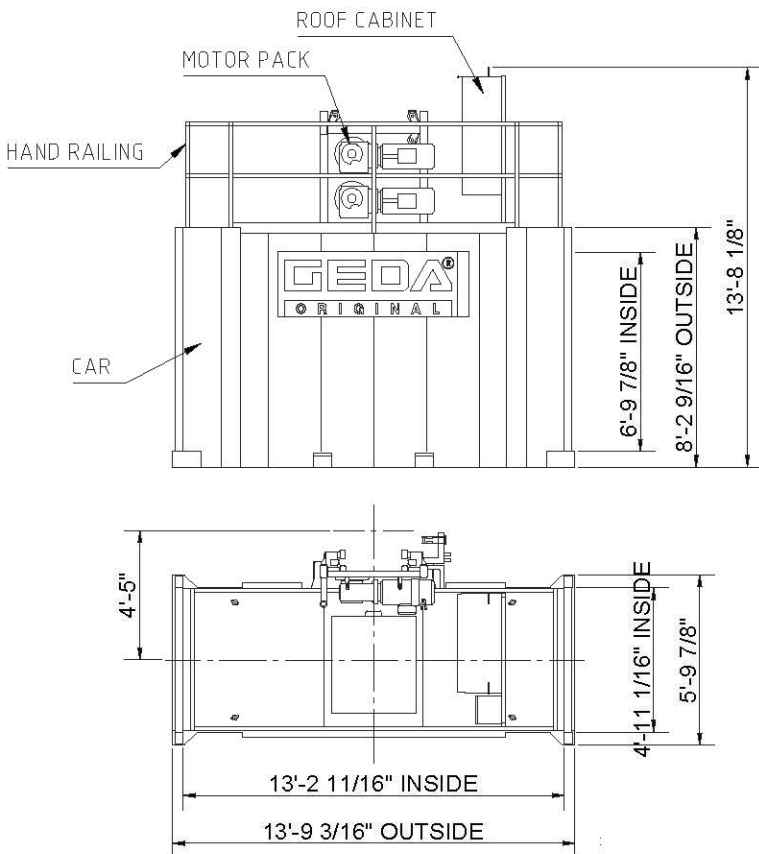

TIE IN DETAILS - SLAB MOUNTED

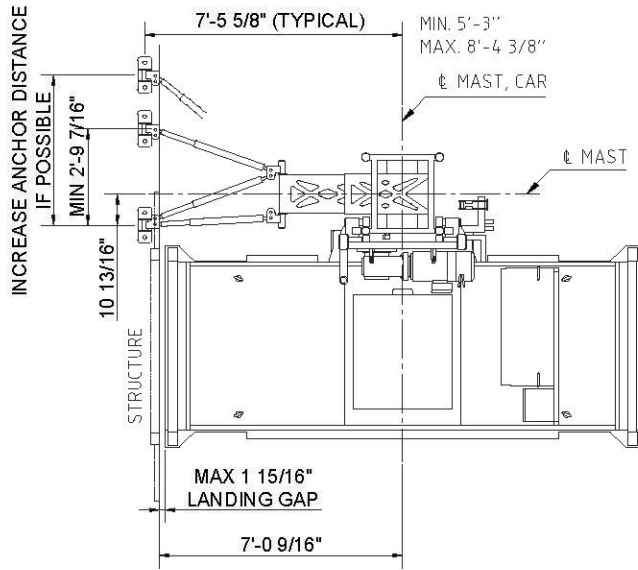

ELEVATION VIEW

TIE IN DETAILS - SLAB MOUNTED WITH LANDING SILL

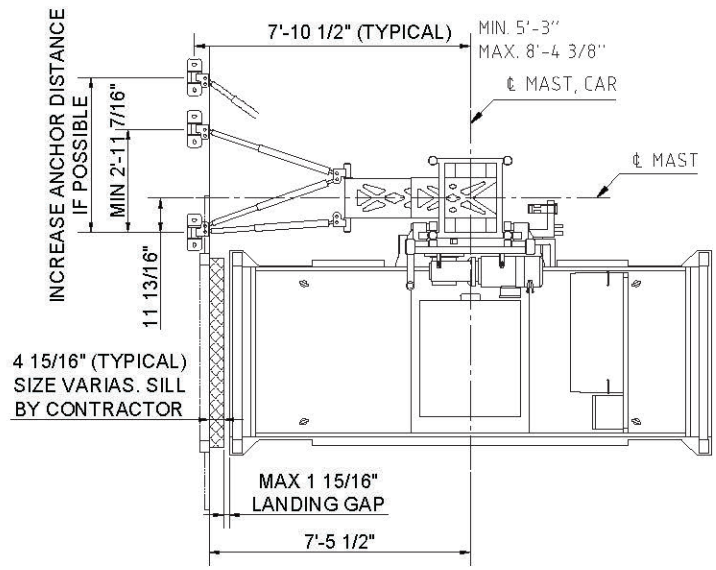

INCLINATION DETAILS

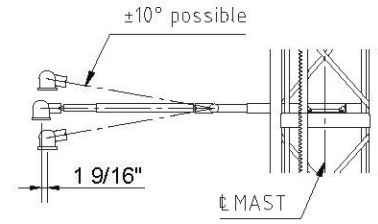
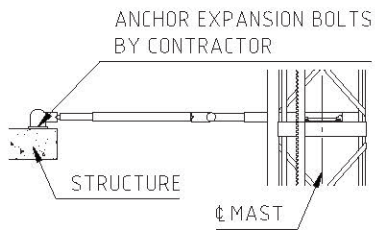

TIE IN PLATE

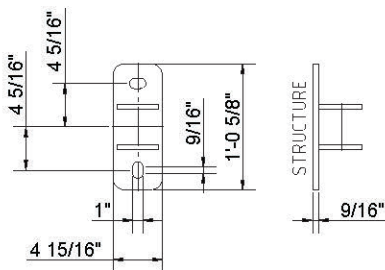

ATTACHMENT POINTS

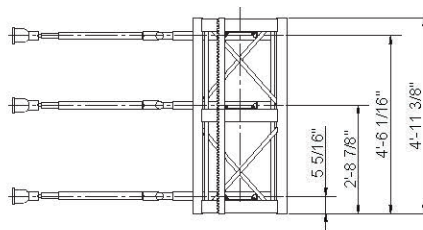

TIE IN LOADS

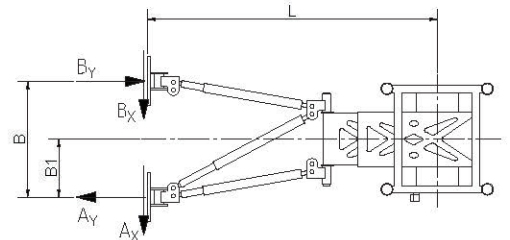

PLEASE SEE GEDA INSTALLATION MANUAL FOR TIE IN LOADS

ALTERNATE MAST TIES OR ANCHORING DISTANCES AVAILABLE. CONTACT GEDA FOR INFORMATION.

TIE IN DETAILS - WALL MOUNTED

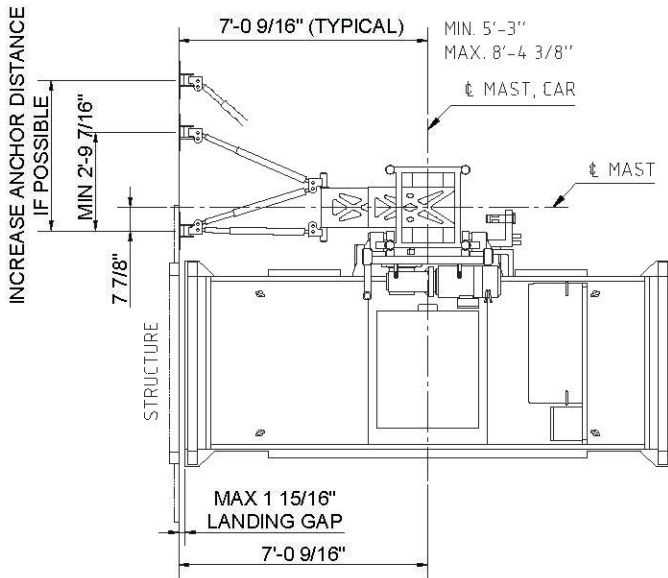

ELEVATION VIEW

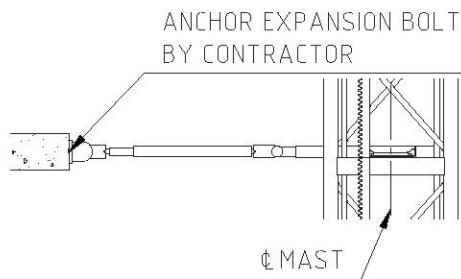

TIE IN DETAILS - WALL MOUNTED WITH LANDING SILL

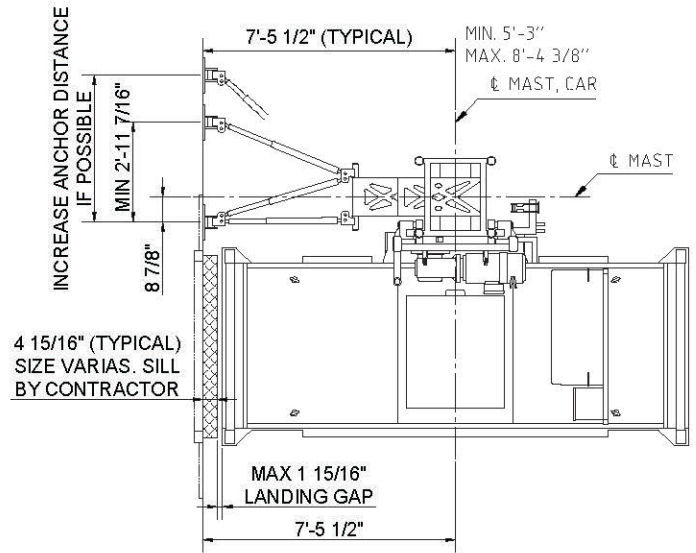

INCLINATION DETAILS

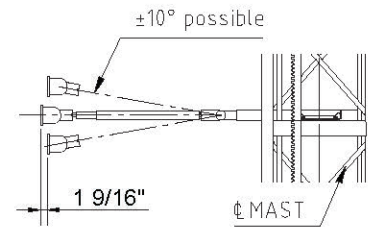

PLAN VIEW BASE ENCLOSURE

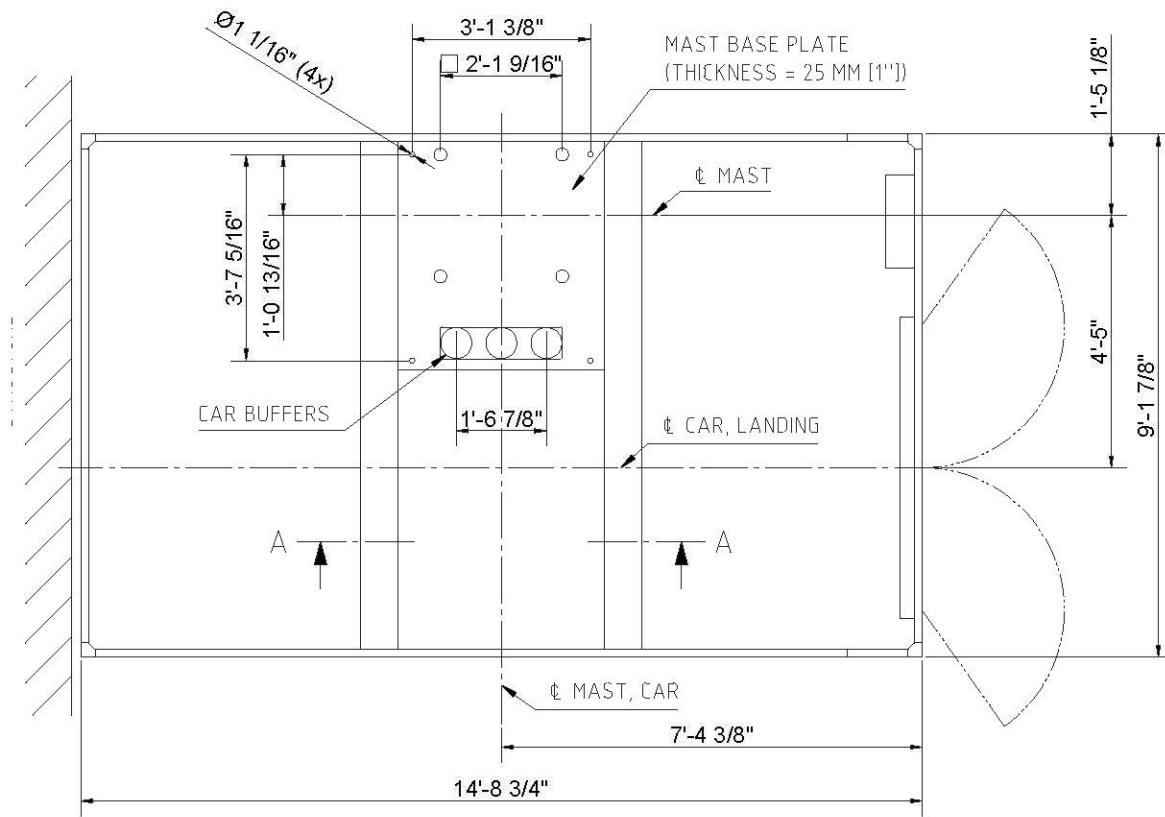

MAST BASE

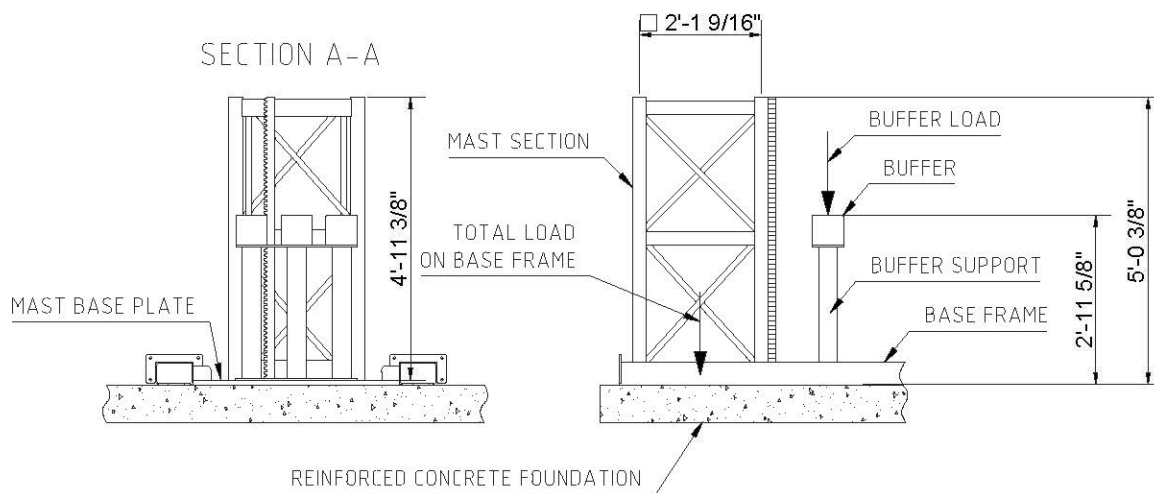

PLEASE SEE GEDA INSTALLATION MANUAL FOR TOTAL LOAD ON BASE FRAME AND BUFFER LOAD.

FOUNDATION PLAN VIEW

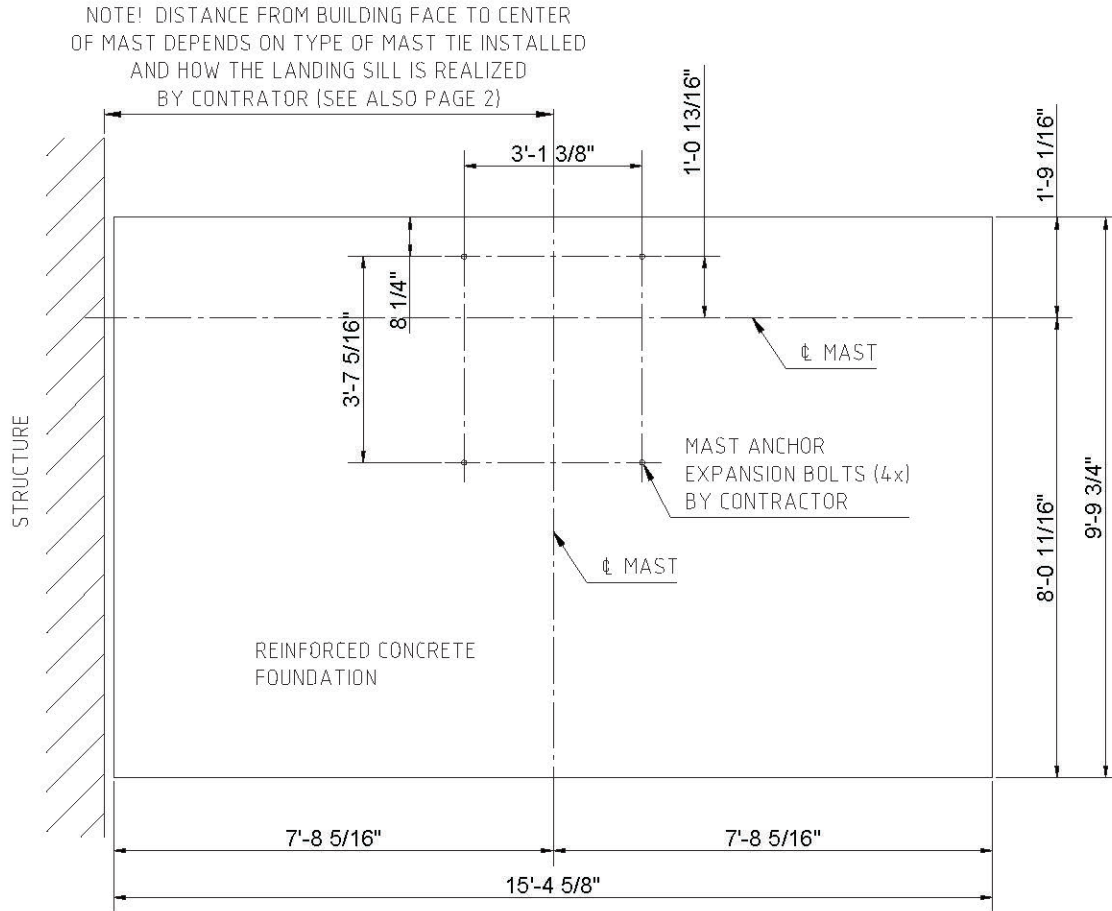

FOUNDATION SIDE VIEW

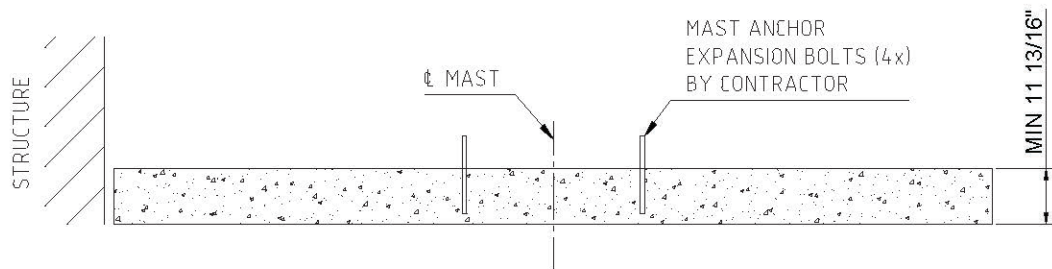

SPECIFICATIONS

MACHINE TECHNICAL DATA SPECS

MACHINE TYPE:	GEDA PH7000
CONFIGURATION:	SINGLE, LEFT CAR
CAPACITY:	7000 POUNDS
LIFTING HEIGHT:	VARIES (MAX 400m)
RATED SPEED:	196 ft/min.
NUMBER OF MOTORS:	2x19 kW (105 Hz)
MOTOR PACK TYPE:	VFC

COMPONENTS WEIGHT

BASE ENCLOSURE:	3200 LBS
CAR:	4200 LBS
MOTORPACK:	1950 LBS
ROOF CABINET:	600 LBS
MAST SECTION SINGLE:	343 LBS
MAST TIE:	230 LBS
CABLE GUIDE	12.5 LBS
CABLE TROLLEY:	165 LBS

POWER SUPPLY REQUIREMENTS (PER CAR)

VOLTAGE:	480 V, 3 PHASE	FREQUENCY:	60 HZ
MAINS FUSES:	100 A	POWER CONSUMPTION	95 kVA



Machinery Directive 2006/42/EG
DIN EN ISO 9001:2008

